



# **PLUNGER VALVE**

**Sizes 8'' - 72''**

# UNDERSTANDING CAVIATION

**What Causes Cavitation** – Cavitation is the process in which a vapor bubble in a liquid rapidly collapses producing a violent shock wave. The shock waves formed by the collapsing bubble can cause significant damage to adjacent pipe, valves, and fittings.

**How Cavitation Works in Simple Terms** – Water has a vapor pressure approximately -14.7psig at sea level and 70 degrees F. A restriction in a pipeline (valve, fitting, orifice plate, etc....) causes higher velocity through the restriction. Due to the conservation of energy, as the velocity increases, the pressure decreases. If the velocity increases to the point that the pressure decreases below the vapor pressure, bubbles form in the water, As the water exits the restriction and the velocity slows (resulting in a higher pressure) the pressure increases above the vapor pressure resulting in the violent collapse of the bubbles. It is the collapsing bubbles that one hears on the pipeline that is the sound of “rocks rolling down the pipe”. Material adjacent to the collapsing bubbles can be destroyed due to the violent nature of the collapse. Cavitation cannot be eliminated but knowing how it works can help us “control” it.

## APPLICATION OF PLUNGER VALVE

**Plunger Valve Applications** – This valve is an excellent choice for flow and pressure control applications where there is potential damage from cavitation. Plunger Valves are a type of control valve that aid in the control of flowing liquids. Shut off valves used for regulating pressure and flow can be damaged by cavitation, which will shorten the life of your Gate Valves, Butterfly Valves, and other Shut-Off Valves when they are used improperly.

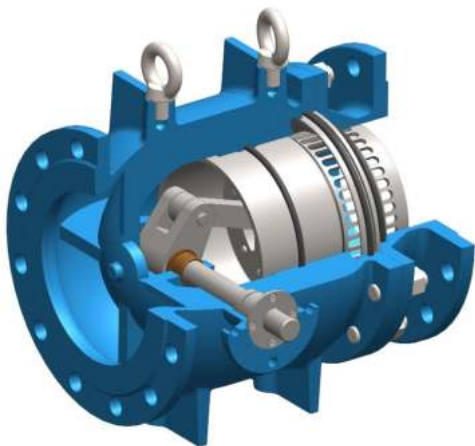

### Plunger Valve Applications

- Reservoir Inlet
- Dam Outlet Control
  - Submersed Discharge
  - Semi-Submersed Discharge
  - Free Discharge
- Turbine Inlet
- Turbine By-pass
- Combined Inlet Regulating and Safety Valve

# DECREASING CAVITATION

**Decreasing Cavitation** – Shut-Off Valves, such as Gate Valves, and Butterfly Valves can restrict the flow of liquids and can cause very high flow velocity in the throttled position. The design of these valves impinging the flow to the pipe walls and the valve interior surfaces. Plunger Valves, by contrast, direct the flow of liquids passing through the plunger valve to the center of the flow element so that the implosions take place in the center of the flow stream away from adjacent pipe and valve surfaces, By redirecting and “controlling” the location of the collapsing bubbles, cavitation damage is significantly reduced.

**The Plunger Valve Advantage** - Valves, such as gate valves are designed to provide unobstructed flow in the fully opened position or to totally obstruct flow when fully closed. These inherently asymmetrical cross sections are unable to provide a linear control over their operating range. In contrast, the plunger Valve has characterized trim that facilitates linear control over the entire operating range. The customized trims allow for characterized flow control for each unique application.

**Centering Bursts** – The Plunger Valve passes the liquid through a characterized element that prevents the cavitation from impinging on the valve and pipeline . surfaces. Liquids travel into the center of the valve or pipeline, and the cavitation “event” is directed away from the adjacent walls. Different valve trim packages allow for customized flow control based on the application. Trim packages include vanned, slotted and perforated trim. A 4Matic Valve consultant can assist with the proper trim package for your application. All anti-cavitation control valves are not made equally and the control of cavitation by directing the flow to the center of the valve is the proven method for controlling cavitation damage.



# PLUNGER VALVE FEATURES

## Features of Plunger Valve

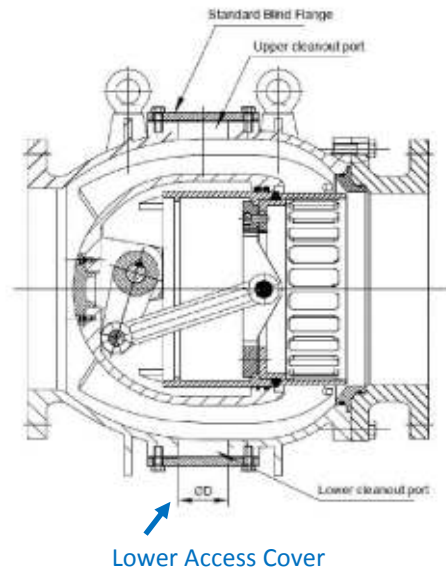

SIZE	FROM 8" TO 24"	FROM 30" TO 36"	FROM 42" TO 60"
d	4"	6"	8"

- Robust Design - Heavy Wall Ductile Iron Body with Class 150 & Class 300 Flanges, PN16/PN25
- Fusion Bond Epoxy Coated
- Top and Bottom Access Covers for Ease of Maintenance and Removal of Collected Debris - Optional
- Linear Flow allowing Excellent Flow Control and Pressure Control
- Custom Trim to Meet Customer Applications
- Designed to Minimize Cavitation, Vibration and Noise
- Low Operating Torque
- ISO Quality Control Standards
- 8" - 72" Size Range with Larger Sizes Available



**Robust Stainless Steel Cage**



# INSTALLATION DIMENSIONS

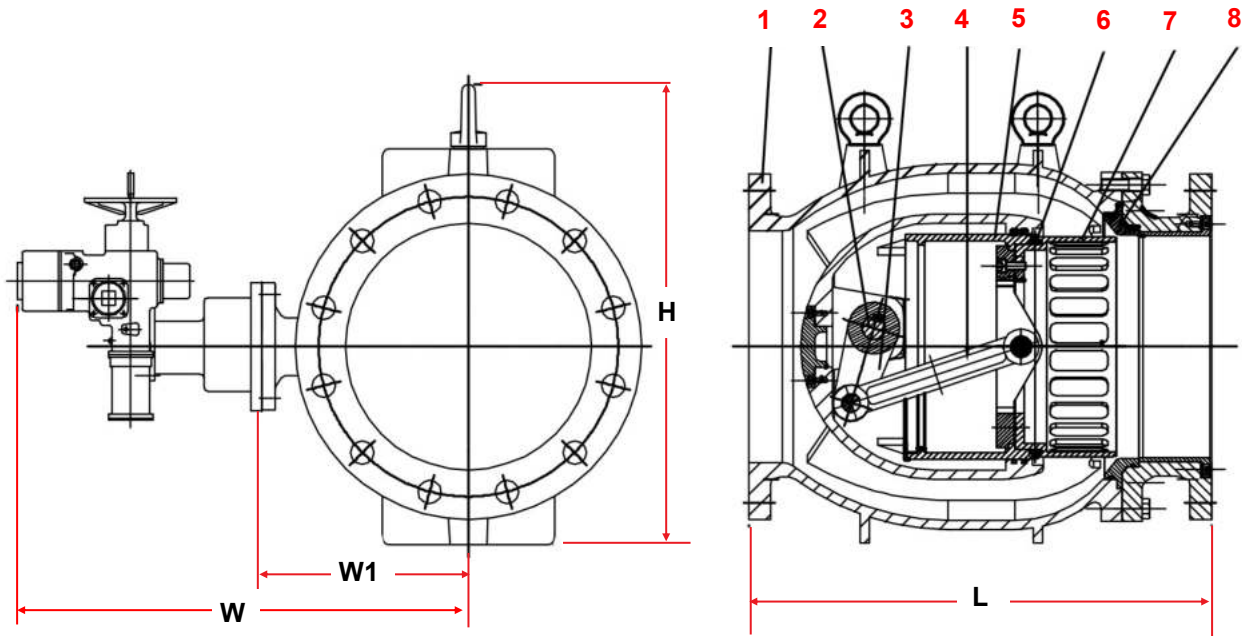

No.	Part Name	Materials
1	Body	Ductile Iron ASTM A536 65-45-12
2	Stem	Stainless Steel 304
3	Crank	Stainless Steel 304
4	Rocker	Stainless Steel 304
5	Cylinder	Stainless Steel 304
6	Sealing Ring	EPDM
7	Cage	Stainless Steel 304
8	Seat	Stainless Steel 304

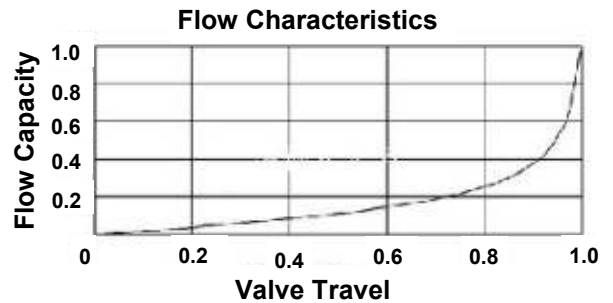

## DIMENSIONS - PLUNGER VALVE:

Size	8"	10"	12"	16"	18"	20"	24"	30"	36"	42"	48"	54"	60"	72"
L	15.7"	19.7"	23.6"	31.5"	35.4"	39.4"	47.2"	59"	70.9"	82.5"	94.5"	106"	118"	140"
H	18"	22"	23.5"	31"	31.5"	35.4"	43"	48"	56"	68"	72"	78.5"	97"	120.5"
W1	8"	10"	11.5"	15.5"	16.5"	18"	24"	26"	33"	35.5"	38.5"	41"	51"	59"
W	20"	23"	24"	28"	30"	32"	33"	37"	42"	47"	51"	59"	70"	80"

# GEARS AND ACTUATORS

## WORM GEAR

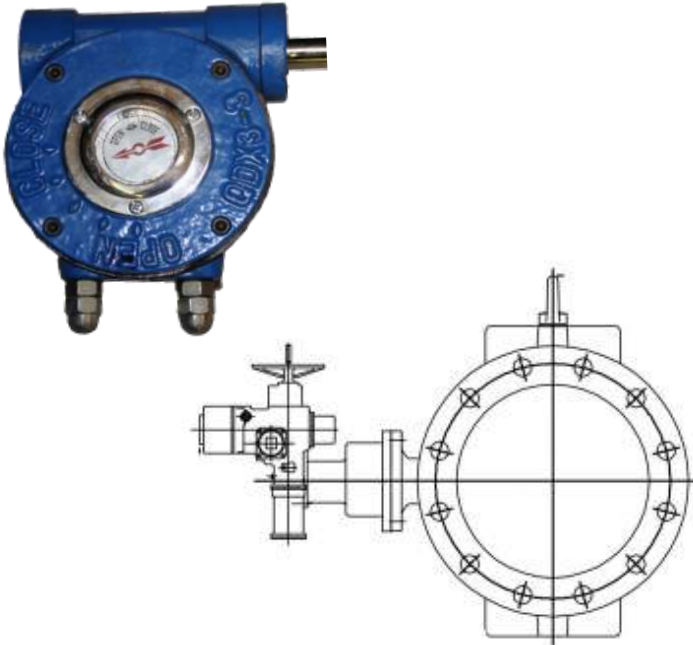

## ACTUATION

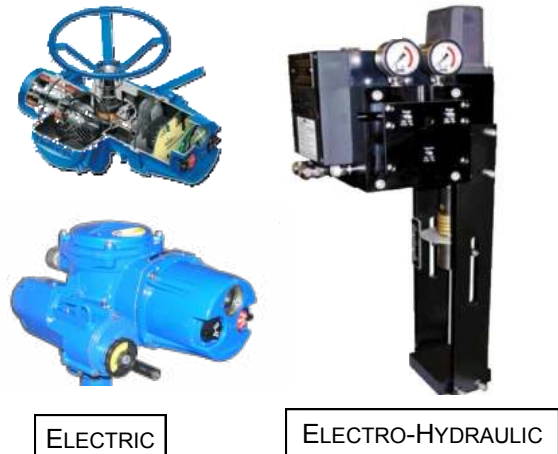

## WORM GEARS:

4Matic Valve's worm gear actuators provide precise quarter-turn actuation in accordance with Standards. Worm gears include externally adjustable mechanical stops to control end of valve travel. These gears are also fusion bonded epoxy coated in accordance with providing more protection and resulting in longer life.

## ELECTRIC/PNEUMATIC/HYDRAULIC /ELECTRO-HYDRAULIC ACTUATORS:

Actuators can be easily adapted to the valve allowing the valve to become integrated with the control system, while also allowing for remote operation. The actuators are built in accordance with Standard for Electric Actuators and are equipped with thermal over-loads, torque switches and limit switches to protect the actuator and valve.

## COMMITMENT TO QUALITY & TECHNICAL ADVANCEMENT:

4Matic Valve is committed to providing the highest quality valves for longer service. 4Matic Valve is recognized around the world for manufacturing the most robust valves on the market. 4Matic Valve strives to provide superior customer service and to provide quality products at competitive prices.

# PLUNGER VALVE SPECIFICATION

## PLUNGER VALVE

The Plunger Valve by 4Matic Valves - Plunger shall be two-part body design and shall feature interior geometry that provides water flow that is guided around the streamlined internal body structure. The valve has a geometrically optimized design, a continuous annular cross-sectional reduction from inlet to throttle cross section, and continuous rise of flow velocity to the exit without producing cavitation.

The 4Matic Plunger Valve assembly consist of a flanged short conical inlet section having an internal cone to divert the water flow into the annular chamber of the body section.

The 4Matic Plunger Valve shall have an oval body section with an inner annular chamber within the body shell. Designed with a customized control cylinder that is part of the internal slider-crank mechanism and is driven by and outside worm gear.

The 4Matic Plunger Valve design shall feature a specially customized designed control cylinder with slotted cage to pass 3/4-inch diameter debris and to minimize cavitation. Slots shall be fully closed when the valve is placed in the closed position. The profile sealing ring in the plunger shall also be seated against the downstream stainless steel seat block in the body when closed.

The Plunger Valve designs the plunger to move in an axially flow direction to reduce or enlarge the annular flow cross section between the outer annular chamber and the inner chamber of the plunger so the water flows through the slots in the customized control cylinder or around the plunger in a digressive manner. The gap where the water flow is fully closed when the valve is in the closed position.

The Plunger Valve is designed, when open during operations, features plunger assembly movement in the up-stream side direction to release water between the plunger and the body or through the slotted control cylinder.

The Plunger Valve design features advanced and retract axial strokes of plunger, guided in the internal body by an internal slider-crank mechanism which minimizes the friction forces on the plunger and guide areas. The internal slider-crank mechanism is driven by an external worm gear. The crank shall have a 78 to 90 degree angle of rotation.

The Plunger Valve guides the plunger with bronze ring or guide rails with bronze welded overlay applied directly on the body. Provided sufficient guide rails or bronze rings for improved range of response frequency of the plunger, to reduce the possibility of operational vibration.

The Plunger Valve on the outside of the plunger seats against an O-ring seal with anti-twist protection and impenetrable to dirt at its upstream end which will be against medium pressure from both the upstream and downstream sides and shall have a profile sealing ring which will seat against a stainless steel seat and the downstream valve body end. The valve shall have a non-wetted and double or-ring sealed actuation shaft to ensure corrosion free operation over the life of the valve. If required, top and bottom clean out access covers are to be provided.

The design of the annular throat cross section in any position of the plunger shall ensure linear regulation of flow.

The profile sealing ring at the downstream side of the valve body or at the downstream side of the plunger shall be exchangeable without the need to dismantle the valve from the pipeline

The design of the internal components and downstream portions of the valve body exposed to high velocity, or erosive flows with stainless steel block or stainless steel liner.

The outside of the plunger shall seat against an elastomer seal ring at the upstream end which will be against pressure from both upstream and downstream sides. The plunger shall seat against the downstream valve body end. The downstream elastomer seal ring shall either be in the body of the plunger valve insert or be mechanically retained in the downstream flange of the valve body by a stainless steel seat ring. The seal shall allow the valve to be drip and bubble tight in both flow directions for the long term. The valve operating shaft shall have seal rings to maintain a drip tight seal regardless of modulation cycles or inactivity. The seal rings will prevent corrosion of the shaft body bore which shall remain dry by design.

## VALVE ACTUATOR

Motion of the plunger shall be controlled by Manual, Hydraulic, Pneumatic or Electric Motor Actuators.

The Plunger Valve shall be actuated with no more than five times the normal operating force required at minimum inlet head conditions. The movement of the plunger shall be controlled by means of an AWWA quarter turn worm gear unit with externally adjustable mechanical stops to limit valve travel in both the open and closed positions. The valve stroke shall equal 78 to 90 degrees plus or minus 2 degrees, whereby the mechanical stops of the worm gear shall be engaged before the full extension or retraction of the plunger. In no instance shall the full output torque of the actuator be allowed to be transmitted to the valve at its end of travel, either open or closed without engaging the travel stops of the worm gear first. The worm gear unit shall be operated by a handwheel, Hydraulic, Pneumatic or electric actuator.



4Matic shows its commitment to providing quality products by manufacturing with the highest grade materials and testing 100% of its valves (rather than random testing). 4Matic is a prominent in the Water works Industry. We provide products and services that consistently meet and exceed our customer's needs as they relate to quality, performance, dependability, operation, and delivery.

